

ENTRY CHECKLIST

The following 3 items must come with your individual work for submission to the contest. Please follow carefully the instructions as explained below.

1. Completed application form 2. Entry Label 3. ID tag for submission work

<ENTRY LABEL>

- If you have more than one entry, a separate entry label is required for each individual entry. (ONE ENTRY = ONE LABEL).
- Please make a copy if you need extra labels.

FILL OUT EXAMPLE

2026 Int'l SILVER ACCESSORIES CONTEST

ENTRY LABEL

*Please fill out the thick-lined space in block letters.

Name of applicant: <div style="text-align: center; font-size: 1.2em; color: blue;">Mary Aida</div>				
Selected Theme: Tick the box <input type="checkbox"/> FUTURE <input type="checkbox"/> Open Theme				
Submission Category: Tick the box <input type="checkbox"/> RING <input type="checkbox"/> ACCESSORIES <input type="checkbox"/> SILVER QUILLING & ORIGAMI <input type="checkbox"/> FRAMED DECORATION <input type="checkbox"/> NEW MOKUME-GANE & NERIKOMI				
Title of submission: <div style="text-align: center; font-size: 1.2em; color: blue;">My Future</div>				
Total # of piece(s): <div style="text-align: center; font-size: 1.5em; color: blue;">1</div>	<table border="1" style="width: 100%; border-collapse: collapse;"> <tr><td style="padding: 2px;">Filled out by office</td></tr> <tr><td style="padding: 2px;">Country:</td></tr> <tr><td style="padding: 2px;">Reg.#:</td></tr> </table>	Filled out by office	Country:	Reg.#:
Filled out by office				
Country:				
Reg.#:				
1	pc(s)			

*If your entry consists of more than 2 pieces, please indicate total number of pieces.

<ID TAG>

- A separate tag is required for each individual work.
- Please attach the tag firmly on the work as explained in the figures below.

FILL OUT EXAMPLE

Front
Applicant's name



Back
Title of submission

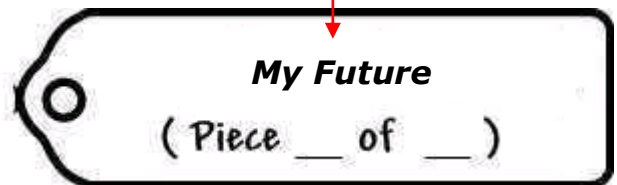

*For multiple submissions, please number each piece.

PENDANT

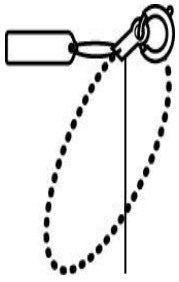

*Please tie on the plate.

EARRINGS

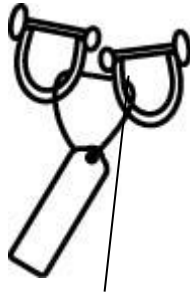

*Please close the screw.

BROOCH

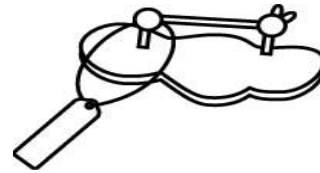

PIERCED EARRINGS



RING



<SIZE LIMITATION>

Please submit the work to fit within the size limitation in the appropriate category.

Ring / Accessories / Silver Quilling & Origami / New Mokume-Gane & Nerikomi

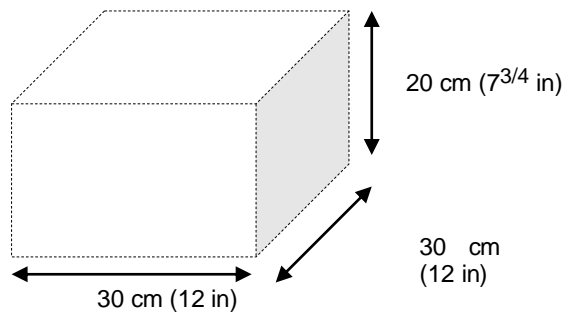

Framed decoration

